

Product data sheet

Characteristics

XMLG100D21

Electronic pressure sensors, Pressure sensors XM, sensor XMLG, 0...100 bar, G 1/4 A (male), 24 V, 4...20 mA

Product availability: Non-Stock - Not normally stocked in distribution facility

Price*: 179.00 USD



Main

Range of product	OsiSense XM
Product or component type	Electronic pressure sensors
Pressure sensor type	Pressure transmitter
Pressure sensor name	XMLG
Pressure sensor size	1450.38 Psi (100 bar)
Type of output signal	Analogue
Quantity per set	Set of 1
Type of packing	Individual
Diameter	0.90 In (22.8 mm)

Complementary

Pressure setting range	0.00...1450.38 Psi (0...100 bar)
Maximum permissible accidental pressure	3263.35 Psi (225 bar)
Destruction pressure	3625.94 Psi (250 bar)
Local display	Without
Electrical circuit type	Control circuit
Current consumption	< 20 mA
Materials in contact with fluid	Ceramic Stainless steel type AISI 303 FPM (Viton) PPS
Operating position	Any position
Protection type	Reverse polarity Load short-circuit
[Uimp] rated impulse withstand voltage	0.5 KV
Response time on output	< 2 ms
Drift of the sensitivity	+/- 0.015 % of measuring range/°C
Drift of the zero point	+/- 0.015 % of measuring range/°C
Measurement accuracy	+/- 0.3 % of the measuring range
Repeat accuracy	+/- 0.1 % of the measuring range
Mechanical durability	10000000 Cycles

Net weight	0.21 Lb(US) (0.095 kg)
Height	2.29 In (58.1 mm)
Length	1.91 In (48.5 mm)
Scale type	Fixed differential

Environment

Standards	EN/IEC 61326-2-3 CE
Product certifications	UL 508 CSA C22.2 No 14 EAC
Protective treatment	TC
Ambient air temperature for operation	5...185 °F (-15...85 °C)
Ambient air temperature for storage	-40...185 °F (-40...85 °C)
NEMA degree of protection	NEMA 4



Ordering and shipping details

Category	21551 - XMLE,XMLF,XMLG PRESSURE SENSORS
Discount Schedule	DS2
GTIN	3389110973242
Nbr. of units in pkg.	1
Package weight(Lbs)	4.80 Oz (136 g)
Returnability	No
Country of origin	CH

Packing Units

Unit Type of Package 1	PCE
Package 1 Height	1.89 In (4.8 cm)
Package 1 width	5.20 In (13.2 cm)
Package 1 Length	4.17 In (10.6 cm)
Unit Type of Package 2	S02
Number of Units in Package 2	12
Package 2 Weight	4.16 Lb(US) (1.888 kg)
Package 2 Height	5.91 In (15 cm)
Package 2 width	11.81 In (30 cm)
Package 2 Length	15.75 In (40 cm)

Offer Sustainability

California proposition 65	WARNING: This product can expose you to chemicals including: Diisononyl phthalate (DINP), which is known to the State of California to cause cancer, and Di-isodecyl phthalate (DIDP), which is known to the State of California to cause birth defects or other reproductive harm. For more information go to www.P65Warnings.ca.gov
REACH Regulation	 REACH Declaration
EU RoHS Directive	Pro-active compliance (Product out of EU RoHS legal scope)  EU RoHS Declaration
Mercury free	Yes
RoHS exemption information	 Yes

Contractual warranty

Warranty	18 months
----------	-----------

Dimensions

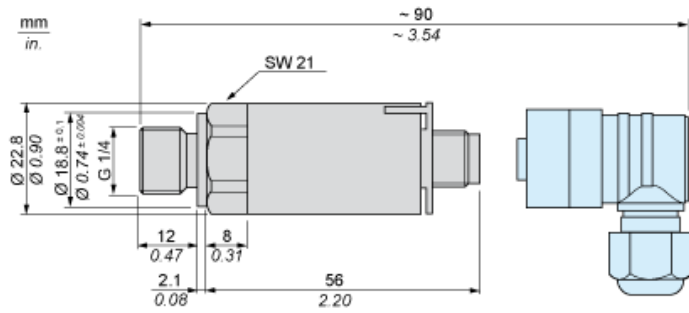

Wiring Diagram

2-Wire Technique (4-20 mA)

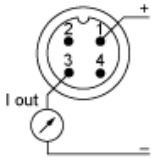

Output Curves

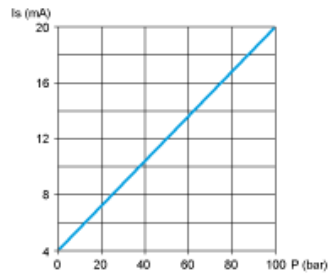

Product Life Status : Commercialised